

ROBOTICS HANDBOOK

IIT PATNA

A SHORT NOTE

This handbook is a valuable resource designed to support and empower fellow college students in their course-related projects, intra and inter college robotics events, and Robocon selections. While we have made every effort to ensure the accuracy of the information provided, it is essential to exercise your own judgment. For further assistance, don't hesitate to contact us:

I would also like to thank Rishav Mitra and Piyush Tewari for proofreading.

PROJECTS AND PROTOTYPING

Panav Arpit Raaj

Captain Robocon IIT Patna

Email: panav_2101ee48@iitp.ac.in

ROBOT OPERATING SYSTEM

Piyush Tewari

Vice-Captain Robocon

Email: piyush_2101ee94@iitp.ac.in

3D MODELLING

Gaganjot Singh

Coordinator Tinkering Lab

Email: gaganjot_2101me22@iitp.ac.in

PARTS

Tejas Tupke

Coordinator Tinkering Lab

Email: tejastupke74@gmail.com

INDEX

Batteries 7

- Lithium Polymer (LiPo) Batteries: 7
- Lithium-ion (Li-ion) Batteries: 7
- Nickel Metal Hydride (NiMH) Batteries: 8
- Nickel Cadmium (NiCd) Batteries: 8
- Lead Acid Batteries: 8

Charging Your Batteries 9

- Balance Charging 9
- Storage Charging 10

Sensors 11

- Accelerometer: 11
- Gyroscope: 12
- Magnetometer: 12
- IR Sensor (Proximity Sensor): 12
- IR Distance Sensor: 13
- Ultrasonic Distance Sensor: 14
- Encoders: 14
- Color Sensor: 14
- Bump Sensor: 15
- IMU: 15

Algorithms & Filters: 16

- PID: 16
- Moving Average: 16
- Low Pass Filter: 17
- High Pass Filter: 17
- Complementary Filter: 17

Microcontrollers 18

Arduino 18

ESP32-WROOM 19

- ESP32 Pinout reference: 19

ESP32-CAM 19

Raspberry Pi 20

Communication 23

Bluetooth Module: 23

- Advantages: 23

Disadvantages: 23

ESP32: 24

Advantages: 24
Disadvantages: 24

Wi-Fi Module: 24

Advantages: 24
Disadvantages: 24

PS2/PS3 Module: 25

Advantages: 25
Disadvantages: 25

Zigbee Module 25

Advantages: 25
Disadvantages: 25

LoRa Module: 26

Advantages: 26
Disadvantages: 26

Miscellaneous Links (For Advanced Study): 26

ROBOT OPERATING SYSTEM(ROS) 27

What is ROS? 27

MATLAB AND SIMULINK 28

Mechanical Design 29

Chapter 1 30

Mechanical Accessories 30

1. Structural Parts 30
 - 1.1 Square Channels or square pipes: 30
 - 1.2 V extrusions: 30
 - 1.3 Shafts 31
 - 1.4 L-plates 31
 - 1.5 Angle Brackets 32
2. Fasteners 32
 - 2.1 Nuts and Bolts 32
 - 2.2 Washers 33
3. Bearings 33
 - 3.1 Ball Bearings 33
 - 3.2 Linear sliders or bearings 34
4. Gears 34

Types of gears: 34

Actuators 35

- 4.1 DC Motors: 35
- 4.2 Brushless DC Motors: 35
- 4.3 Servo Motors: 36
- 4.3 GEAR MOTORS 36
- 4.5 Solenoids: 37
- 4.5 Stepper Motors: 37
- 4.6 Pneumatics & Hydraulic Actuators: 38

Chapter 2 38

Power Transmission 38

- 1 Key and Key slot 38
- 2 Gear Train: 39
- 3 Chain Sprockets 39
- 4. V belts 40
- 4. Timing Belts 40

Wheels and Drives 41

- 3.1 Omni Wheels 41
- 3.2 Mecanum Wheels: 41
- 3.3 Differential Wheels 42
- 3.4 Castor Wheels: 42

Various Types of Drives 43

- 3.1 Two-wheel Differential: 43
- 3.2 Three wheeled Omni Drive: 43
- 3.3 Four Wheeled Omni Drive: 44
- 3.4 Four Wheel Mecanum Drive: 45

Designing in Solidworks: 45

Image Processing 46

Purpose of Image processing 46

Types 47

Drones and avionics 48

- Learn the Basics: 48
- Familiarize yourself with the drone regulations in your country or region. 48
- Start with a small and affordable drone for beginners to practice flying and develop piloting skills. 49
- Follow safety guidelines to ensure responsible and safe drone operation. 49
- Resources and Communities: 49

Artificial Intelligence 49

Machine Learning 49

Computer vision

Natural Language Processing

Computer 49

Image Processing 50

Natural Language Processing 50

Neural Networks 50

1. Andrew NG - Coursera 50
2. CS 229 50
3. Deep Learning - DeepLearning.ai (Coursera) 50
4. Image Processing - OpenCV Tutorials 50
5. **Books : 50**

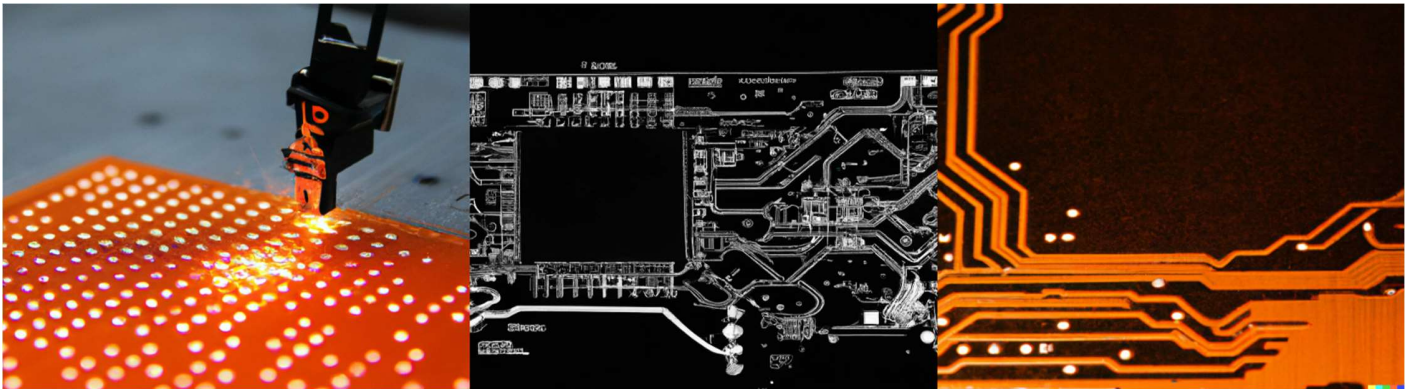

BATTERIES

LITHIUM POLYMER (LIPO) BATTERIES:



- a. Advantages: High energy density, lightweight, flexible form factor, high discharge rates, and low self-discharge rate. Can be manufactured in various shapes and sizes to fit specific designs.
- b. Disadvantages: Requires specialized charging and discharging circuits to prevent overcharging or discharging, sensitive to mishandling or physical damage (may result in swelling, fire, or explosion), shorter overall lifespan compared to Li-ion batteries.

LiPo batteries are a variant of lithium-ion batteries that utilize a polymer electrolyte. They are commonly used in robotics, particularly in applications where weight and space constraints are crucial, such as drones and small mobile robots. However, their sensitivity to mishandling and the requirement for proper charging and discharging management make them less forgiving compared to other battery technologies.

LITHIUM-ION (LI-ION) BATTERIES:



- a. Advantages: High energy density, long cycle life, lightweight, low self-discharge rate, and high power output.
- c. Disadvantages: Relatively expensive, risk of thermal runaway or explosion if improperly handled or damaged, limited availability of rare materials required for production.

NICKEL METAL HYDRIDE (NIMH) BATTERIES:



- d. Advantages: Higher energy density than older battery technologies like Nickel Cadmium (NiCd), no memory effect, relatively environmentally friendly.
- e. Disadvantages: Lower energy density compared to Li-ion, self-discharge rate is higher, limited cycle life, heavier and bulkier.

NICKEL CADMIUM (NICD) BATTERIES:

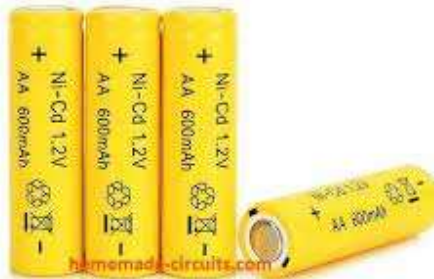

- f. Advantages: Good performance at low temperatures, relatively low cost, ability to deliver high currents.
- g. Disadvantages: Lower energy density compared to Li-ion and NiMH, memory effect (reduced capacity if not fully discharged before recharging), toxic and environmentally hazardous due to cadmium content, relatively heavy.

LEAD ACID BATTERIES:



- h. Advantages: Low cost, availability, ability to deliver high currents, suitable for deep discharge applications.
- i. Disadvantages: Low energy density, large and heavy, limited cycle life, significant self-discharge rate, environmentally hazardous due to lead and acid content.

CHARGING YOUR BATTERIES

Now that you know about batteries and their different implementations, it is crucial to understand how to charge them effectively to ensure long usage and prevent accidents.



Traditionally, each LiPo cell is 3.7 volts with a maximum voltage of 4.2V. For a three-cell LiPo battery, the voltage will be $3.7V \times 3 = 11.1V$ and the maximum voltage will be $4.2 \times 3 = 12.6V$. Your battery should not exceed its maximum voltage. Helpfully, balance chargers read the voltage and notify you when your battery is at its full voltage.

BALANCE CHARGING

The LiPo balance charging setting

If you're not in a hurry and care about your battery's well-being, then balance charging is the way to go. With balance charging, the voltage of each cell becomes readable for the charger through the balance connector. This lets the charger balance the cells, which will increase the lifespan of your battery in the long run.



To balance charge your LiPo battery:

1. Connect the power connectors to the balance charger's power slots. Remember that black goes to negative, and red goes to positive.
2. Connect the clamps of the power connectors to your battery. Make sure that you connect red to red and black to black.
3. Insert the balance connector of your battery to the designated slot in the balance charger.
4. Turn on the balance charger and go to the Balance Charge setting. This is usually the second setting.
5. Select your battery type.
6. Check the connections and once you're sure, press the Start button and then confirm.
7. The balance charger will now charge and balance your battery cells.

STORAGE CHARGING



The LiPo storage charge setting

If you plan on not using your LiPo battery for a while, it's a good idea to storage charge it before you store it.

LiPo batteries, like most batteries, slowly discharge on their own. If you store a discharged battery for a long time, the battery might discharge below its safe range and then become dead.

On the other hand, if you fully charge a battery and leave it unused, the cells will unbalance, which can harm your battery and reduce its lifespan and functionality. Using the storage charge method will charge or discharge the battery to an appropriate value; not fully discharged nor fully charged.

To storage charge your battery:

1. Connect the power connectors to the balance charger. Black goes to negative, and red goes to positive.
2. Connect the crocodile clamps of the power connectors to your battery. Red to red and black to black.
3. Turn on the balance charger and go to the Storage Charge setting.
4. Select your battery type.
5. Check the connections, then press Start and confirm.
6. The balance charger will discharge or charge your battery to the proper storing voltage.
7. Once you have storage charged your battery, it's best to store it in somewhere cool like a fridge. Make sure to put it in a bag and wrap it to prevent moisture from getting in.

These were the two most important charging modes, for more details you can refer here:
<https://www.makeuseof.com/how-to-charge-a-lipo-battery/>

SENSORS

ACCELEROMETER:



An accelerometer measures acceleration (change in speed) of anything that it's mounted on. How does it work? Inside an accelerator, **MEMS devices** are tiny micro-structures that bend due to momentum and gravity. When it experiences any form of acceleration, these tiny structures bend by an equivalent amount which can be electrically detected.

http://www.societyofrobots.com/sensors_accelerometer.shtml

<https://learn.sparkfun.com/tutorials/accelerometer-basics>

GYROSCOPE:



A **gyroscope** is a device used for measuring or maintaining [orientation](#) and [angular velocity](#).^{[1][2]} It is a spinning wheel or disc in which the axis of rotation is free to assume any orientation by itself. When rotating, the orientation of this axis is unaffected by tilting or rotation of the mounting, according to the [conservation of angular momentum](#).

<https://en.wikipedia.org/wiki/Gyroscope>

MAGNETOMETER:



The **digital compass** gives measurements based on Earth's magnetic field for robot navigation. Inside this, commonly available MEMS are tiny nanostructures that bend due to electromagnetic fields. When this MEMS experiences any form of EM field, the tiny structures bend by an amount that can be electrically detected. Cheaper digital compasses usually have a resolution of around +/- 5 degrees, but newer and better ones can detect with better accuracy.

http://www.societyofrobots.com/sensors_digitalcompass.shtml

IR SENSOR (PROXIMITY SENSOR):



The Infrared emitter detector circuit is very useful if you plan to make a [line following robot](#), or a robot with the basic object or obstacle detection. **Infrared emitter detector** pair sensors are fairly easy to implement, although involved some level of **testing** and **calibration** to get right. They can be used for obstacle detection, motion detection, transmitters, [encoders](#), and color detection (such as for line following).

http://www.societyofrobots.com/schematics_infraredemitdet.shtml

IR DISTANCE SENSOR:



The Sharp IR Range Finder works by the process of **triangulation**. A pulse of light (wavelength range of 850nm +/-70nm) is emitted and then reflected back (or not reflected at all). When the light returns it comes back at an angle that is dependent on the distance of the reflecting object. Triangulation works by detecting this reflected beam angle - by knowing the angle, distance can then be determined.

http://www.societyofrobots.com/sensors_sharpirrange.shtml

ULTRASONIC DISTANCE SENSOR:



Everyone knows how sonar works. A sound gets emitted, then you 'see' your surroundings based on the sound coming echoing back. This is because sound takes time to travel distances. Farther the distance, the longer it takes for the sound to come back. http://www.societyofrobots.com/sensors_sonar.shtml

ENCODERS:

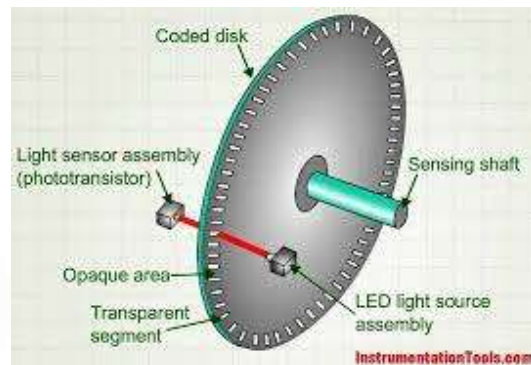

The encoder is a sensor attached to a rotating object (such as a wheel or motor) to measure rotation. By measuring rotation your robot can do things such as determine displacement, velocity, acceleration, or the angle of a rotating sensor. A typical encoder uses an optical sensor(s), a moving mechanical component, and a special reflector to provide a series of electrical pulses to your [microcontroller](#). These pulses can be used as part of a [PID feedback control system](#) to determine translation distance, rotational velocity, and/or angle of a moving robot or robot part.

http://www.societyofrobots.com/sensors_encoder.shtml

COLOR SENSOR:



The color sensor detects the color of the surface, usually in the RGB scale. Color is the result of interaction between a light source, an object, and an observer. In the case of reflected light, light falling on an object will be reflected or absorbed depending on surface characteristics, such as reflectance and transmittance. For example, green paper will absorb most of the reddish and bluish part of the spectrum while reflecting the greenish part of the spectrum, making it appear greenish to the observer.

http://www.societyofrobots.com/sensors_color.shtml

BUMP SENSOR:

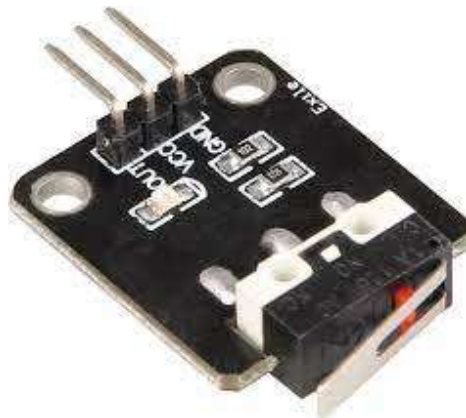

Tactile Bump Sensors are great for **collision detection**, but the circuit itself also works fine for user buttons and switches as well. They usually implement a mechanical button to short the circuit, pulling the signal line high or low.

http://www.societyofrobots.com/sensors_tactbumpswitch.shtml

IMU:

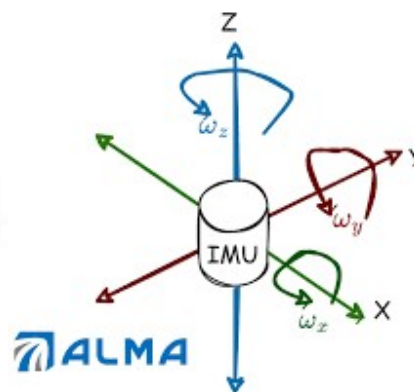

An **inertial measurement unit (IMU)** is an electronic device that measures and reports a body's specific **force**, angular rate, and sometimes the magnetic field surrounding the body, using a combination of **accelerometers** and **gyroscopes**, sometimes also **magnetometers**. IMUs are typically used to maneuver **aircraft**, including **unmanned aerial vehicles** (UAVs), among many others, and **spacecraft**, including **satellites** and **landers**.

https://en.wikipedia.org/wiki/Inertial_measurement_unit

Bluetooth Module: <https://www.electronicshub.org/hc-05-bluetooth-module/>
<https://www.youtube.com/watch?v=E-1w7dL3Cps>

Wifi Module: <https://www.youtube.com/watch?v=p06NNRq5NTU>

ALGORITHMS & FILTERS:

PID:

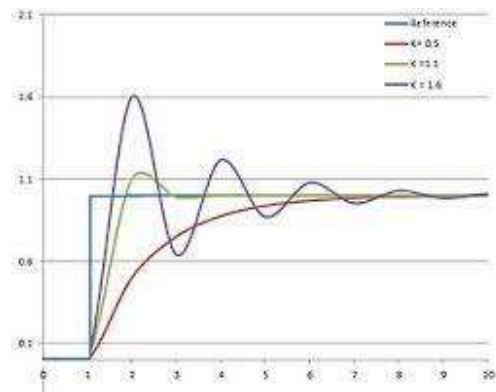

A proportional integral derivative controller (PID controller) is a common method of controlling robots. PID theory will help you design a better control equation for your robot.

A PID controller is a way to control robots more effectively. By understanding PID theory, you can create a better formula for controlling your robot's movements, ensuring it responds accurately to changes and performs tasks more precisely.

Actuator Output = $K_p * (\text{distance from goal}) + K_d * (\text{change in error}) + K_i * (\text{accumulative error})$

http://www.societyofrobots.com/programming_PID.shtml

<https://www.youtube.com/watch?v=wkfEZmsQqiA&list=PLn8PRpmsu08pQBqjxYFXSsODEF3Jq-mm-y>

https://www.researchgate.net/publication/303806333_Control_Systems_in_Robotics_A_Review

<https://www.youtube.com/watch?v=fusr9eTceEo> <https://www.electronicshub.org/arduino-line-follower-robot/>

<http://www.ostan.cz/LineFollowerSimulator/>

MOVING AVERAGE:

In [statistics](#), a **moving average** (**rolling average** or **running average**) is a calculation to analyze data points by creating series of [averages](#) of different subsets of the full data set. It is also called a **moving mean (MM)**^[1] or **rolling mean** and is a type of [finite impulse response](#) filter. Given a series of numbers and a fixed subset size, the first element of the moving average is obtained by taking the average of the initial fixed subset of the number series. Then the subset is modified by "shifting forward"; that is, excluding the first number of the series and including the next value in the subset.

https://en.wikipedia.org/wiki/Moving_average

LOW PASS FILTER:

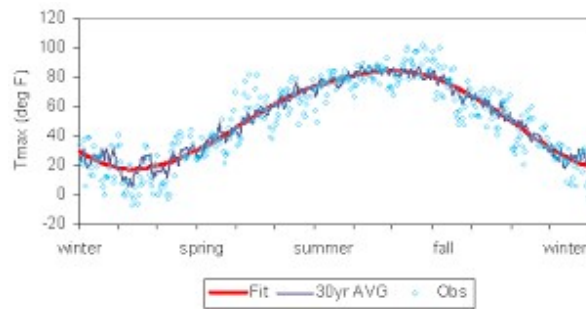

A **low-pass filter (LPF)** is a [filter](#) that passes [signals](#) with a [frequency](#) lower than a certain [cutoff frequency](#) and [attenuates](#) signals with frequencies higher than the cutoff frequency. The exact [frequency response](#) of the filter depends on the [filter design](#). The filter is sometimes called a **high-cut filter**, or **treble-cut filter** in audio applications.

A low-pass filter is the complement of a [high-pass filter](#). https://en.wikipedia.org/wiki/Low-pass_filter

HIGH PASS FILTER:

A **high-pass filter (HPF)** is an [electronic filter](#) that passes [signals](#) with a [frequency](#) higher than a certain [cutoff frequency](#) and [attenuates](#) signals with frequencies lower than the cutoff frequency. The amount of [attenuation](#) for each frequency depends on the filter design. A high-pass [filter](#) is usually modeled as a [linear time-invariant system](#). It is sometimes called a **low-cut filter** or **bass-cut filter**.^[1] High-pass filters have many uses, such as blocking DC from circuitry sensitive to non-zero average voltages or [radio frequency](#) devices. They can also be used in conjunction with a [low-pass filter](#) to produce a [band pass filter](#).

https://en.wikipedia.org/wiki/High-pass_filter

COMPLEMENTARY FILTER:

The idea behind the complementary filter is to take slow-moving signals from an accelerometer and fast-moving signals from a gyroscope and combine them.

Accelerometer gives a good indicator of orientation in static conditions.

The gyroscope gives a good indicator of tilt in dynamic conditions.

So the idea is to pass the accelerometer signals through a low-pass filter and the gyroscope signals through a high-pass filter and combine them to give the final rate.

This principle can also be used for filtering signals of other co-related sensors.

$y[n] = (1 - \alpha) * x[n] + \alpha * y[n-1]$ //use this for angles obtained from accelerometers $x[n]$ is the pitch/roll/yaw that you get from the accelerometer $y[n]$ is the filtered final pitch/roll/yaw

<https://sites.google.com/site/myimuestimationexperience/filters/complementary-filter>

MICROCONTROLLERS

ARDUINO

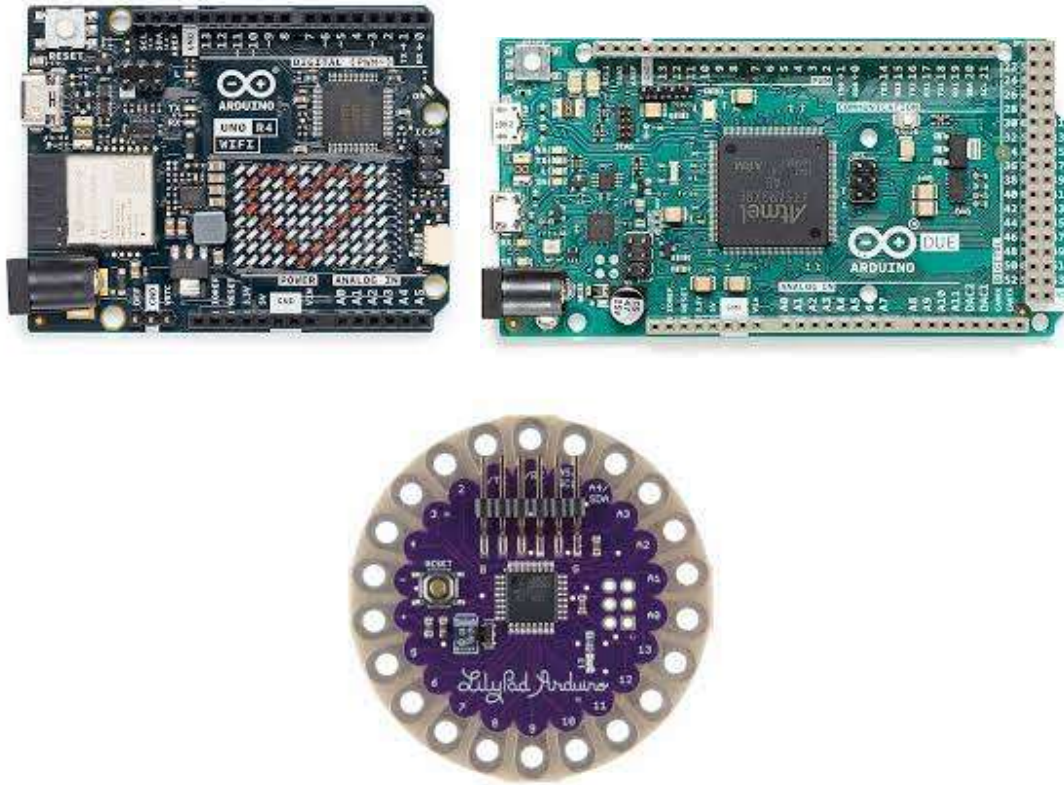

Arduino is an open-source electronics platform based on easy-to-use hardware and software. [Arduino boards](#) are able to read inputs - light on a sensor, a finger on a button, or a Twitter message - and turn it into an output - activating a motor, turning on an LED, publishing something online. You can tell your board what to do by sending a set of instructions to the microcontroller on the board.

Here are some links which will be useful to you for introduction to Arduino:

<https://learn.sparkfun.com/tutorials/what-is-an-arduino> <https://learn.sparkfun.com/tutorials/installing-arduino-ide>
<https://learn.sparkfun.com/tutorials/data-types-in-arduino>

Arduino Tutorials YouTube:

Jeremy Blum <https://www.youtube.com/playlist?list=PLA567CE235D39FA84>
<https://www.youtube.com/playlist?list=PLPK2I9Knytq5s2dk8V09thBmNI2q5pRSr>

Some Basic Arduino Based Projects:

<https://programmingelectronics.com/category/project-based/>

ESP32-WROOM



The ESP32-WROOM-32D is a powerful and versatile Wi-Fi and Bluetooth module based on the ESP32 microcontroller. It features a dual-core processor, ample memory, and various peripherals, making it ideal for IoT applications. The module supports 2.4 GHz Wi-Fi and Bluetooth 4.2 connectivity, enabling seamless communication with other devices. With its compact size and extensive features, the ESP32-WROOM-32D offers a reliable and cost-effective solution for wireless connectivity in a wide range of projects.

ESP32 Arduino Core: <https://github.com/espressif/arduino-esp32>

ESP32 PINOUT REFERENCE: <https://randomnerdtutorials.com/esp32-pinout-reference-gpios/>

ESP32 Forum: <https://esp32.com/forums/>

ESP32 Tutorials and Projects: <https://randomnerdtutorials.com/projects-esp32/>

ESP32 API Reference: <https://docs.espressif.com/projects/esp-idf/en/latest/esp32/api-reference/index.html>

ESP32-CAM



ESP-CAM is a development board based on the ESP32 system-on-a-chip (SoC) that integrates Wi-Fi and Bluetooth connectivity, along with a camera module. It is designed for projects that require video streaming, image capture, and processing capabilities. The ESP32 chip, developed by Espressif Systems, is widely used for IoT (Internet of Things) applications due to its low power consumption, high performance, and rich set of features.

The ESP-CAM board features an OV2640 camera module, which is a low-cost, small-sized camera capable of capturing 2 megapixel (1600x1200) images and video at a maximum resolution of 1600x1200 pixels. It supports various image formats, such as JPEG, BMP, and YUV.

The ESP32 chip provides a powerful platform for image processing and video streaming applications. It offers a dual-core processor with up to 240 MHz clock speed, ample RAM and flash memory, and a wide range of peripherals, including GPIOs, SPI, I2C, UART, and more. This makes it suitable for real-time image processing tasks, such as face detection, object recognition, and motion tracking.

The ESP-CAM board can be programmed using the Arduino IDE or the ESP-IDF (ESP32 IoT Development Framework). Espressif provides a comprehensive set of libraries and examples to facilitate camera-related tasks, such as capturing images, streaming video over Wi-Fi, and implementing image processing algorithms.

For more information on ESP-CAM and its capabilities, you can refer to the following resources:

ESP32 Camera Web Server Tutorial by Random Nerd Tutorials: <https://randomnerdtutorials.com/esp32-cam-video-streaming-web-server-camera-home-assistant/>

ESP32-CAM Video Streaming and Face Recognition Tutorial by Rui Santos: <https://randomnerdtutorials.com/esp32-cam-video-streaming-face-recognition-arduino-ide/>

ARDUINO NANO



The Arduino Nano is a compact microcontroller board based on the ATmega328P chip. It's easy to use and popular among beginners and experienced makers. Here's a concise introduction to the Arduino Nano along with project tutorial links:

Use the Arduino Software (IDE) for programming the Nano.

It supports various sensors, actuators, and modules through its pins.

Arduino Nano Pinout Diagram: [Link](#)

Project Tutorials:

LED Blink: [Tutorial](#)

Temperature and Humidity Monitor: [Tutorial](#)

Line Follower Robot: [Tutorial](#)

Wireless Weather Station: [Tutorial](#)

RASPBERRY PI PICO:



The Raspberry Pi Pico is a microcontroller board developed by the Raspberry Pi Foundation. It features the RP2040 microcontroller with a dual-core ARM Cortex-M0+ processor. The Pico offers flexible I/O options, including GPIO pins, SPI, I2C, UART, and PWM. It can be programmed using MicroPython, C/C++, or CircuitPython.

Important Links:

Raspberry Pi Pico Official Documentation: [Link](#)

Raspberry Pi Pico Pinout Diagram: [Link](#)

Raspberry Pi Pico Projects and Tutorials: [Link](#)

ESP8266:



The ESP8266 is a low-cost Wi-Fi microchip with a built-in TCP/IP stack. It is widely used for IoT applications and projects requiring Wi-Fi connectivity. The ESP8266 can be programmed using the Arduino IDE or MicroPython. It offers GPIO pins, I2C, SPI, UART, and Wi-Fi capabilities.

Important Links:

ESP8266 Community: [Link](#)

ESP8266 Arduino Core Documentation: [Link](#)

ESP8266 Projects and Tutorials: [Link](#)

You can explore these resources and project tutorials to learn more about the Raspberry Pi Pico and ESP8266, and start building exciting projects with these microcontrollers.

STM32

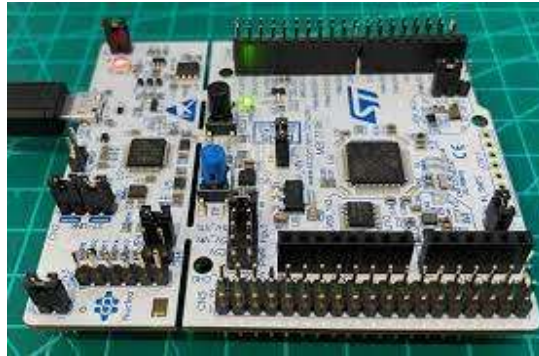

The STM32 microcontroller boards are a series of development boards based on the ARM Cortex-M processor architecture. They are manufactured by STMicroelectronics and offer a wide range of features and capabilities. Here's a description of STM32 boards and some references for further exploration:

STM32 Board Description:

The STM32 boards are available in various series, such as STM32F, STM32L, and STM32H, with different performance levels and features.

They are built around 32-bit ARM Cortex-M cores, offering high performance and low power consumption.

STM32 boards come in different form factors, including Nucleo, Discovery, and Evaluation boards, catering to different development needs.

These boards provide a range of peripherals, including GPIO, UART, SPI, I2C, USB, and more, allowing for versatile project development.

They can be programmed using various development environments, including STM32CubeIDE, Arduino IDE, Keil, and PlatformIO.

References for Further Exploration:

Official STM32 Website: [Link](#)

STM32CubeIDE: [Link](#)

STM32 Nucleo Boards: [Link](#)

STM32 Discovery Boards: [Link](#)

STM32 Reference Manuals and Datasheets: [Link](#)

The official STM32 website provides comprehensive information, including datasheets, reference manuals, application notes, and software tools. STM32CubeIDE is a popular integrated development environment (IDE) for programming STM32 boards. The Nucleo and Discovery boards are commonly used for prototyping and development.

RASPBERRY PI

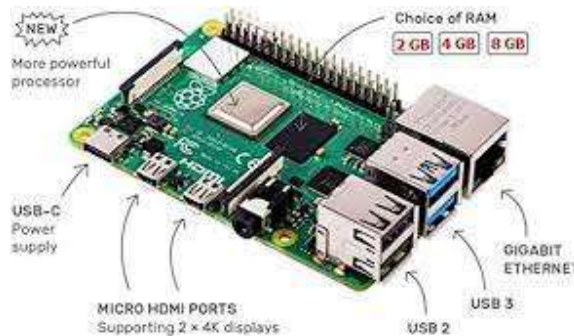

The Raspberry Pi is a low-cost, credit-card-sized computer that plugs into a computer monitor or TV, and uses a standard keyboard and mouse. It is a capable little device that enables people of all ages to explore computing and to learn how to program in languages like Scratch and Python. It's capable of doing everything you'd expect a desktop computer to do, from browsing the internet and playing high-definition video, to making spreadsheets, word-processing, and playing games.

YouTube Tutorial Links:

https://www.youtube.com/playlist?list=PLQVvvaa0QuDesV8WWHLLXW_avmTzHmJLv

<https://www.youtube.com/playlist?list=PLPK2I9Knytg67nkvpnnl81ossAHfOgmgU>

COMMUNICATION

BLUETOOTH MODULE:



ADVANTAGES:

- Low power consumption, making it suitable for battery-powered projects.
- Simplicity of use and compatibility with various devices.
- Provides relatively short-range communication, ideal for local interactions.

DISADVANTAGES:

- Limited data transfer rate compared to Wi-Fi.
- Requires pairing and may have limited compatibility with older Bluetooth versions.

ESP32:



ADVANTAGES:

Dual-mode Bluetooth (Classic and BLE) allows for compatibility with a wide range of devices.
Wi-Fi capability provides access to local networks and the internet.
Offers a high level of performance and a wide range of features.

DISADVANTAGES:

Higher power consumption compared to other wireless modules.
Slightly more complex to set up and configure compared to simpler wireless modules.

WI-FI MODULE:

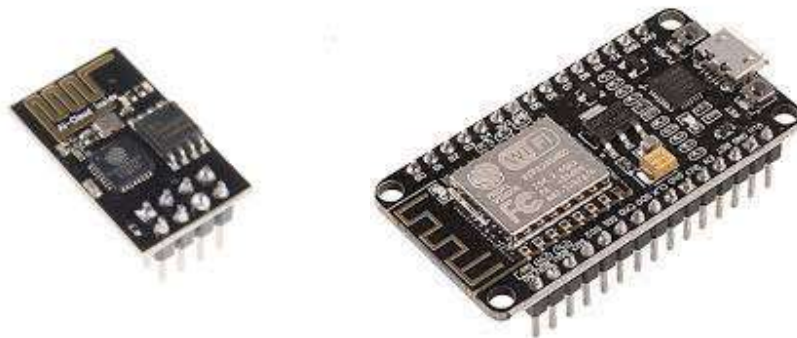

ADVANTAGES:

High data transfer rate, enabling faster communication.
Access to local networks and the internet, allowing for cloud connectivity.
Widely available and supported, with extensive documentation and community support.

DISADVANTAGES:

Higher power consumption compared to other wireless modules.
May require more complex setup and configuration compared to simpler wireless modules.

PS2/PS3 MODULE:



ADVANTAGES:

Allows wireless communication with PlayStation 2 or PlayStation 3 controllers.
Ideal for gaming applications or projects that require joystick input.
Relatively simple to set up and use.

DISADVANTAGES:

Limited range compared to other wireless modules.
Limited to communication with PlayStation controllers only.

ZIGBEE MODULE



ADVANTAGES:

Low-power and low-data-rate wireless communication protocol.
Enables mesh networking, allowing devices to form self-healing networks.
Suitable for applications requiring reliable and robust communication.
Offers decent range and interference tolerance.

DISADVANTAGES:

Requires additional Zigbee coordinator devices or gateways for integration with Arduino or Raspberry Pi.

Slightly more complex to set up compared to other wireless modules.

LORA MODULE:



ADVANTAGES:

Long-range wireless communication technology, suitable for applications covering large areas.

Low power consumption, making it ideal for battery-powered projects.

Supports point-to-point and point-to-multipoint communication.

Well-suited for IoT applications and projects requiring long-range sensor data transmission.

DISADVANTAGES:

Lower data transfer rates compared to other wireless modules like Wi-Fi or Zigbee.

Requires specific LoRa gateways or receivers for integration with Arduino or Raspberry Pi.

Regulations and frequencies may vary across region

MISCELLANEOUS LINKS (FOR ADVANCED STUDY):

PWM: <https://learn.sparkfun.com/tutorials/pulse-width-modulation>

<https://learn.sparkfun.com/tutorials/integrated-circuits> <https://learn.sparkfun.com/tutorials/analog-vs-digital>

<https://learn.sparkfun.com/tutorials/logic-levels> <http://www.arduino.cc/en/Guide/Introduction>

<http://learn.sparkfun.com/tutorials/how-do-i-power-my-project>

SERIAL COMMUNICATION: <https://learn.sparkfun.com/tutorials/serial-communication>

I2C: <https://learn.sparkfun.com/tutorials/i2c>

ADC: <https://learn.sparkfun.com/tutorials/analog-to-digital-conversion> <https://learn.sparkfun.com/tutorials/pcb-basics>

ROBOT OPERATING SYSTEM(ROS)

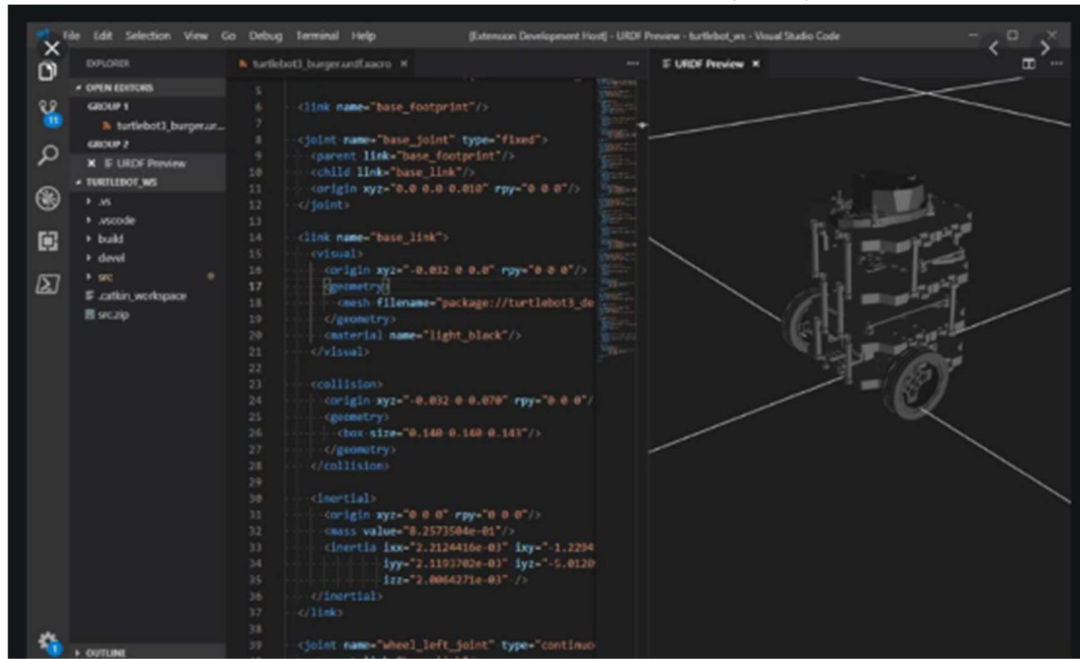

Ever wondered how complex Autonomous Systems like Tesla's Self-driving car or Autonomous Drones handle onboard communication? Of course, writing all the control logic along with the distribution of sensor feed from the ground up in Arduino or Raspberry Pi won't help. This is where ROS comes into the picture.

WHAT IS ROS?

ROS stands for Robot Operating System and is an OS for your robot. It runs on top of a standard Linux installation on a variety of different types of computers, such as a Raspberry Pi or High-end processors like Qualcomm Snapdragon or Jetson tx2. Here's what it does.

1. ROS provides a standard way to connect all your sensors (cameras, distance sensors, analog to digital converters, IMU) and actuators (drive motors, servos, lights) together with the control software that makes the decisions. It's the glue that ties all that together and saves you the tedium of figuring out how to pass that data around on your robot.
2. ROS helps you easily have multiple computers or microprocessors communicate on your robot, or across a network. You can, for example, drive a ROS robot from your desktop computer over the network, or have a more powerful computer handle compute-intensive tasks rather than doing them on the robot.
3. ROS provides libraries for complex behaviors like map building and localization, the use of LIDAR and other sensors, and handling video. Once you get your robot interfaced with ROS in the way it expects, you can integrate these functions without writing them from scratch!
4. ROS also has some extremely useful tools for visualizing the data from sensors and where that data is flowing.

5. You can test ROS software in a simulator without running it on real robot hardware. In fact, you can write and run ROS software using no hardware beyond a basic computer.

Code that you write and test on the simulator can be easily transferred to a real robot.

GETTING STARTED WITH ROS:

The following tutorials provide an exhaustive list of all ROS concepts and commands:

1. <http://wiki.ros.org/ROS/Tutorials> (ROS wiki contains application-based tutorials too for eg: Turtlebot where you can test out your knowledge).
2. <http://www.clearpathrobotics.com/assets/guides/melodic/ros/>
3. <https://rsl.ethz.ch/education-students/lectures/ros.html>
4. <https://online-learning.tudelft.nl/courses/hello-real-world-with-ros-robot-operating-system-s/>

Along with these, the following Youtube channels usually have brief playlists to help you get acquainted with ROS and its applications:

1. <https://www.youtube.com/channel/UCt6Lag-vv25fTX3e11mVY1Q>
2. <https://www.youtube.com/channel/UCNPP3C-ZK3mwpG2x89VE-2Q>

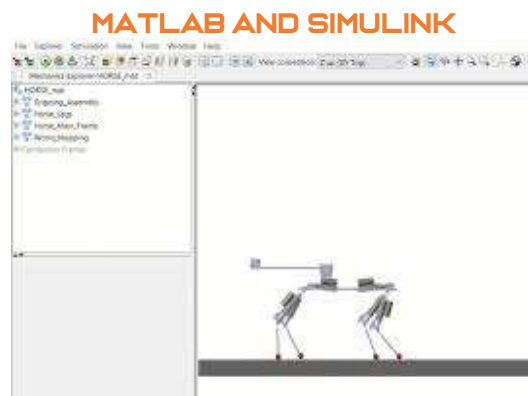

MATLAB is a scientific tool that is designed for scientists and engineers. It is a programming platform with which you can analyze data, develop algorithms and create models and applications. MATLAB is mostly used in industry and education for numerous fields such as signal processing and communications, control systems, and various Computations.

CHAPTER 1

MECHANICAL ACCESSORIES

1. STRUCTURAL PARTS

1.1 SQUARE CHANNELS OR SQUARE PIPES:



These are hollow square extrusions that are used in making the physical structure of the robot or any machine. They come in various sizes and materials according to the requirement in terms of size and strength respectively.

1.2 V EXTRUSIONS:

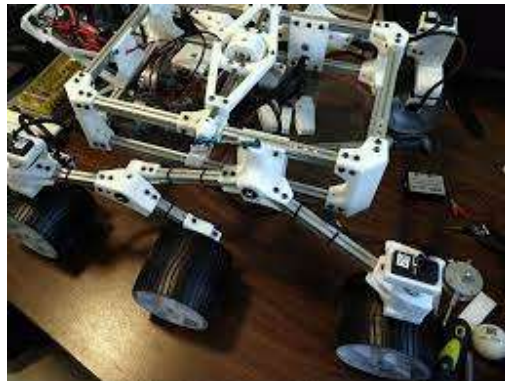

These are customized cross-sectional extruded structural parts used in making robots. One of their main advantages over regular square pipes is their enhanced strength and the presence of several accessories that makes the construction of a structure, using V extrusion, easier.

[Extrusion : YouTube video link](#)

[Extrusion 2 : YouTube Video Link](#)

1.3 SHAFTS

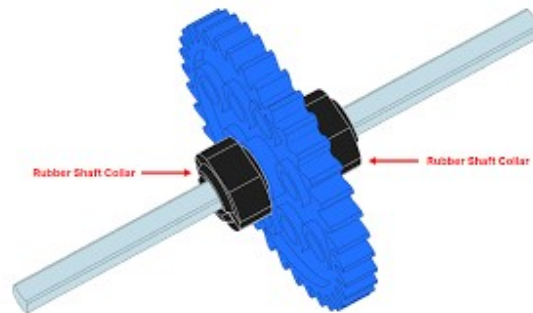

A shaft is a [rotating machine element](#), usually circular in cross-section, which is used to [transmit](#) power from one part to another, or from a machine that produces power to a machine that absorbs power. The various members such as [pulleys](#) and [gears](#) are mounted on it.

1.4 L-PLATES



These are the mechanical parts that are used to provide strength to the structure and also make the structure planar.

[L plates use : YouTube video link](#)

1.5 ANGLE BRACKETS



These are the mechanical parts that are used to provide strength to the structure and also used to join two square pipes perpendicular to each other.

2. FASTENERS 2.1 NUTS AND BOLTS



Nuts and bolts are the mechanical parts that are used to join or fasten various structural parts. There are different types of nuts and bolts present today that have different designs according to different applications.

2.2 WASHERS



A washer is a thin plate (typically disk-shaped) with a hole (typically in the middle) that is normally used to distribute the load of a [threaded fastener](#), such as a [screw](#) or [nut](#).

[Bolts : YouTube Video Link](#)

[Nuts : YouTube Video Link](#)

[Washers : YouTube video Link](#)

3. BEARINGS

A bearing is a [machine element](#) that constrains relative motion to only the desired motion, and reduces [friction](#) between [moving parts](#). The design of the bearing may, for example, provide for free [linear](#) movement of the moving part or for free rotation around a fixed axis.

3.1 BALL BEARINGS



The purpose of a ball bearing is to support or facilitate rolling motion by reducing rotational friction and support [radial](#) and [axial](#) loads.

[Bearing : Link YouTube](#)

3.2 LINEAR SLIDERS OR BEARINGS



The purpose of a linear sliders or bearing is to support or facilitate rolling motion by reducing rotational friction between guide and rail and support corresponding loads.

[Linear Sliders or Bearings : Link YouTube](#)

[Linear Sliders or Bearings 2 \(watch only initial 4 minutes\): Link YouTube](#)

4. GEARS

A gear or cogwheel is a [rotating machine](#) part having cut *teeth*, or cogs, which mesh with another toothed part to transmit [torque](#). Geared devices can change the speed, torque, and direction of a [power source](#).

TYPES OF GEARS:

- | | |
|-------------------|------------|
| 1. Spur | 2. Helical |
| 3. Double helical | 4. Bevel |
| 5. Spiral bevels | 6. Hypoid |
| 7. Crown | 8. Worm |

[Types of Gears : YouTube video Link](#)

WATCH THESE VIDEOS IN ORDER TO GET AN IDEA OF MECHANICAL ACCESSORIES

1. [Manufacturing Video 1](#)
2. [Manufacturing Video 2](#)

ACTUATORS

4.1 DC MOTORS:



From the start, DC motors seem quite simple. Apply a voltage to both terminals, and *wEEEEEEEE* it spins. But what if you want to control which direction the motor spins? Correct, you reverse the wires. Now what if you want the motor to spin at half that speed? You would use less voltage. But how would you get a robot to do those things autonomously? How would you know what voltage a motor should get? Why not 50V instead of 12V? What about motor overheating? To know the answers follow the link.

http://www.societyofrobots.com/actuators_dcmotors.shtml

4.2 BRUSHLESS DC MOTORS:



e

In order to make the operation more reliable, more efficient, and less noisy the recent trend has been to use brushless D.C (BLDC) motors. They are also lighter compared to brushed motors with the same power output. The brushes in conventional D.C motors wear out over the time and may cause sparking. As a result the conventional D.C motors require occasional maintenance. Controlling the brush sparking in them is also a difficult affair. Thus the brushed D.C motor should never be used for operations that demand long life and reliability. For this reason, BLDC motors are used in most of the modern devices. Efficiency of a BLDC motor is typically around 85-90%, whereas the conventional brushed motors are only 75-80% efficient. BLDC motors

are also suitable for high speed applications (10000 rpm or above). The BLDC motors are also well known for their better speed control. http://www.societyofrobots.com/actuators_brushlessmotors.shtml

4.3 SERVO MOTORS:

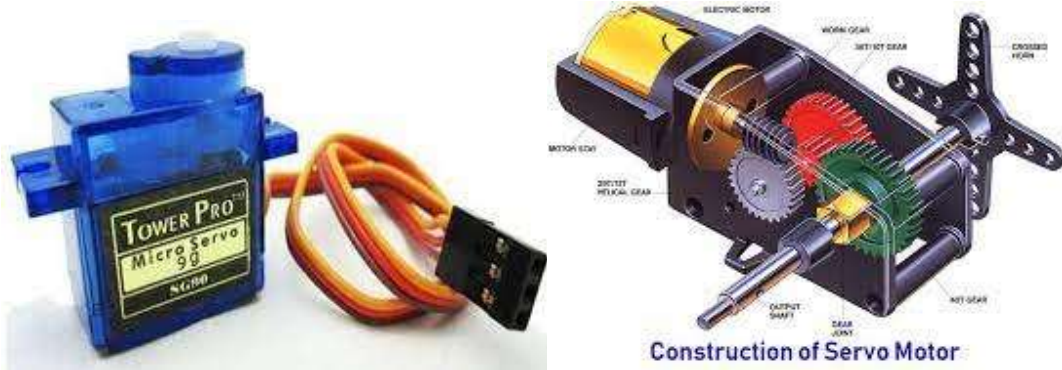

A **servomotor** is a rotary actuator or linear actuator that allows for precise control of angular or linear position, velocity and acceleration.^[1] It consists of a suitable motor coupled to a sensor for position feedback. It also requires a relatively sophisticated controller, often a dedicated module designed specifically for use with servo motors. http://www.societyofrobots.com/actuators_servos.shtml

4.3 GEAR MOTORS



Geared motors are basically motors which have been coupled with a gear, IN most cases they are used to slow down the motor to fit our purposes, Keep in mind that geared motors have higher torque than steppers but less standing torque than steppers, Which means they can deliver high torque in moving from point a to point b, but If stopped midway, they can be displaced more easily than a stepper from the desired position, in between point a and b.

These are also used in Drive Mechanisms

4.5 SOLENOIDS:

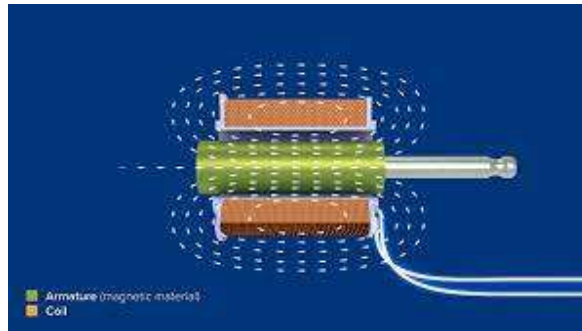

Solenoids are actuators capable of linear motion. They can be electromechanical (AC/DC), hydraulic, or pneumatic driven - all operating on the same basic principles. Give it energy and it will produce a linear force. They are great for pushing buttons, hitting keys on a piano, valve operators, and even for jumping robots. DC solenoids operate on the same basic principles as a **DC motor**.

http://www.societyofrobots.com/actuators_solenoids.shtml

4.5 STEPPER MOTORS:

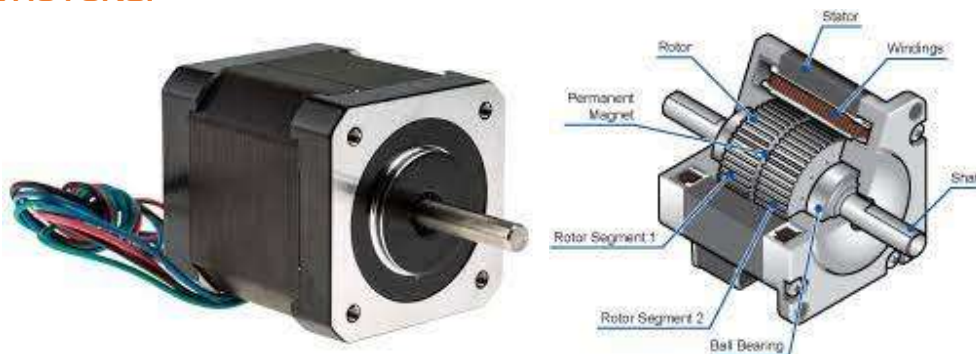

Stepper Motors work under a very similar principle to DC motors, except they have many coils instead of just one. So to operate a stepper motor, one must activate these different coils in particular patterns to generate motor rotation. So stepper motors need to be sent **patterned commands** to rotate. These commands are sent as high and low logic over several lines, and must be pulsed in a **particular order** and **combination**. Steppers are often used because each 'step,' separated by a set step angle, can be counted and used for **feedback control**. For example, a 10 degree step angle stepper motor would require 36 commands to rotate 360 degrees.

http://www.societyofrobots.com/actuators_steppers.shtml

[Stepper Motors : YouTube Video Link](#)

4.6 PNEUMATICS & HYDRAULIC ACTUATORS:

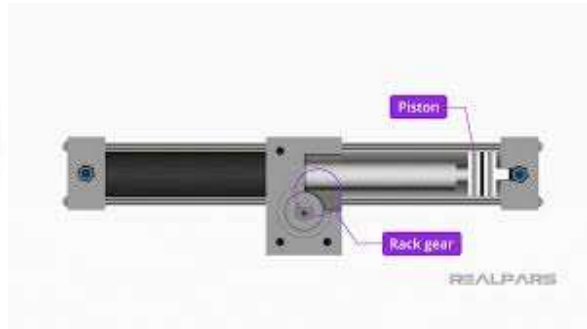

A **pneumatic control valve actuator** converts energy (typically in the form of compressed air) into mechanical motion. The motion can be rotary or linear, depending on the type of actuator.

Similarly Hydraulic actuators use liquid (typically water) for energy transfer.

http://www.robotplatform.com/knowledge/actuators/types_of_actuators.html

[Pneumatics tutorials \(a bit longer video but clears all the fundamentals of Pneumatic actuators\): video Link YouTube](#)

CHAPTER 2

POWER TRANSMISSION

1 KEY AND KEY SLOT

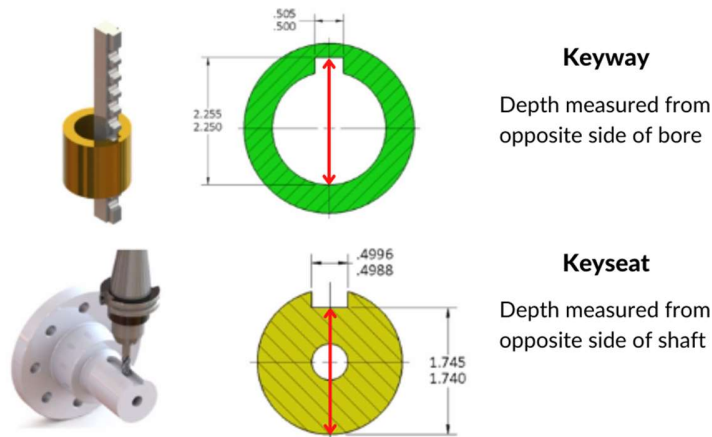

www.gdandtbasics.com



A key is a [machine element](#) used to connect a rotating machine element to a shaft. The key prevents relative rotation between the two parts and may enable torque transmission. For a key to function, the shaft and rotating machine element must have a keyway and a keyseat, which is a slot and pocket in which the key fits. The whole system is called a keyed joint. A keyed joint may allow relative axial movement between the parts.

2 GEAR TRAIN:

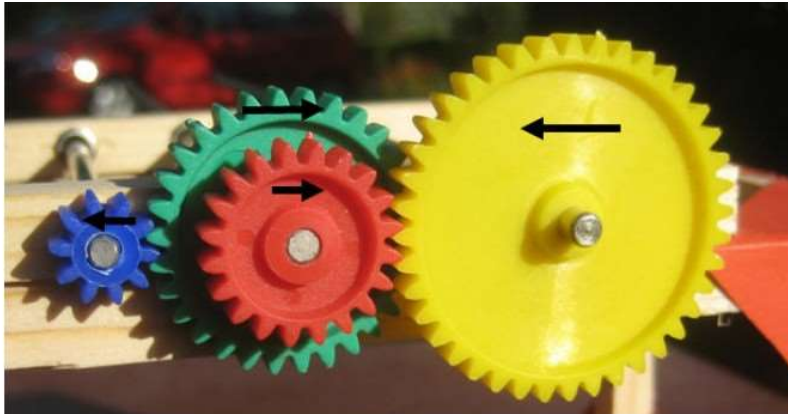

The *rotational* motion of one shaft is transmitted to another with the help of gears. The transferring of power can be either in intersecting or parallel shafts. It is the most frequently used mechanical transmission system in robots. The added advantage of the gears is that the speed can be *decreased or increased* according to the operation.

[Gear trains in robotics: YouTube video link](#)

3 CHAIN SPROCKETS



Sprockets are used in bicycles, motorcycles, cars, tracked vehicles, and other machinery either to transmit rotary motion between two shafts where gears are unsuitable or to impart linear motion to a track, tape, etc. Perhaps the most common form of sprocket may be found in the bicycle, in which the pedal shaft carries a large sprocket-wheel, which drives a chain, which, in turn, drives a small sprocket on the axle of the rear wheel. Early automobiles were also largely driven by sprocket and chain mechanism, a practice largely copied from bicycles.

[Chain and Sprockets: YouTube Video Link](#)

3. V BELTS



4.

A belt is a loop of flexible material used to link two or more rotating shafts mechanically, most often parallel. Belts may be used as a source of motion, to transmit power efficiently, or to track relative movement. Belts are looped over pulleys and may have a twist between the pulleys, and the shafts need not be parallel.

[V belts : YouTube Video Link](#)

4. TIMING BELTS



A toothed belt; timing belt; cogged belt; cog belt; or synchronous belt is a flexible belt with teeth molded onto its inner surface. It is designed to run over matching toothed pulleys or sprockets. Toothed belts are used in a wide array of mechanical devices, where high-power transmission is desired. [Timing Belts : YouTube Video Link](#)

CHAPTER 3

WHEELS AND DRIVES

3.1 OMNI WHEELS



Omni wheels or poly wheels, similar to Mecanum wheels, are wheels with small discs around the circumference which are perpendicular to the turning direction. The effect is that the wheel can be driven with full force, but will also slide laterally with great ease. These wheels are often employed in holonomic drive systems.

3.2 MECANUM WHEELS:



The Mecanum wheel is a design for a wheel that can move a vehicle in any direction. It is sometimes called the Ilon wheel after its inventor, Bengt Erland Ilon, who came up with the idea when he was an engineer with the Swedish company Mecanum AB.

It is a conventional wheel with a series of rollers attached to its circumference. These rollers typically each have an axis of rotation at 45° to the plane of the wheel and at 45° to a

line through the center of the roller parallel to the axis of rotation of the wheel.

3.3 DIFFERENTIAL WHEELS



Differential Wheels are the normal Wheels that are used in various day-to-day appliances.

3.4 CASTOR WHEELS:



A caster (also *castor* according to some dictionaries) is a wheeled device typically mounted to a larger object that enables relatively easy rolling movement of the object. Casters are essentially special housings that include a wheel, facilitating the installation of wheels on objects.

VARIOUS TYPES OF DRIVES

3.1 TWO-WHEEL DIFFERENTIAL:

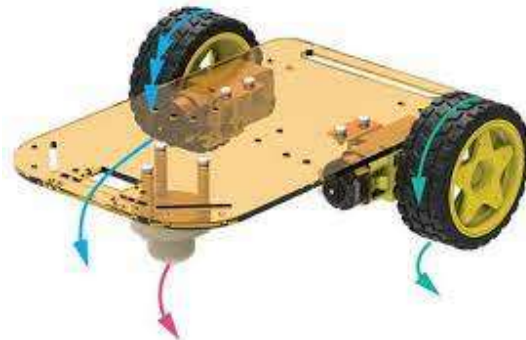

A differential wheeled robot is a mobile robot whose movement is based on two separately driven wheels placed on either side of the robot body. It can thus change its direction by varying the relative rate of rotation of its wheels and hence does not require an additional steering motion.

To balance the robot, additional wheels or casters may be added.

[Two Wheel Differential Drive : YouTube Video Link](#)

3.2 THREE WHEELED OMNI DRIVE:

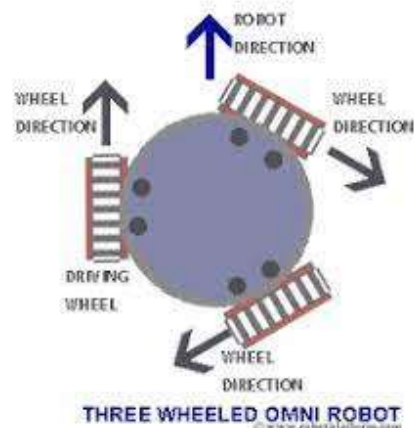

A three wheel design offers greater traction as any reactive force is distributed through only three points and the robot is well balanced even on uneven terrain. This design also reduces an additional wheel compared to a

4 wheeled robot which makes it cost effective (yes, these wheels are expensive). In few instances, I have see that designing a three wheeled Omni robot is simpler and can drive more straight than a four wheeled robot, although I would still vote for a 4 wheeled robot.

Few designers add two wheels parallel to each other and one wheel perpendicular to the two wheels which is a better design or a compromise between three and four wheeled Omni-drive robots.

3. [wheel Omni Drive : YouTube video Link](#)

3.3 FOUR WHEELED OMNI DRIVE:

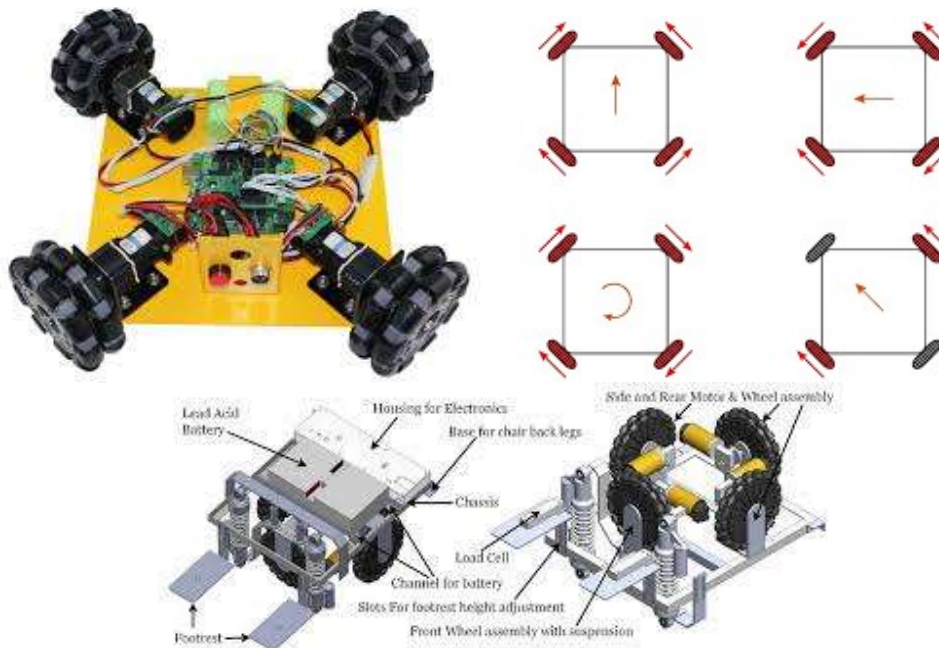

In 4 wheel design, 4 Omni wheels are attached at 90° to each other. This means any two wheels are parallel to each other and other two wheels perpendicular. The first and the major benefit is the simplified calculation. Since there are two pairs of wheels, each pair requires only one calculation and all four wheels require only two calculations. Also at any point there are two driving wheels and two free wheels. This makes the two driving wheels 100% efficient and drivers the robot at higher speed compared to 3-wheel design.

4. [wheel Omni Drive : YouTube Video Link](#)

3.4 FOUR WHEEL MECANUM DRIVE:

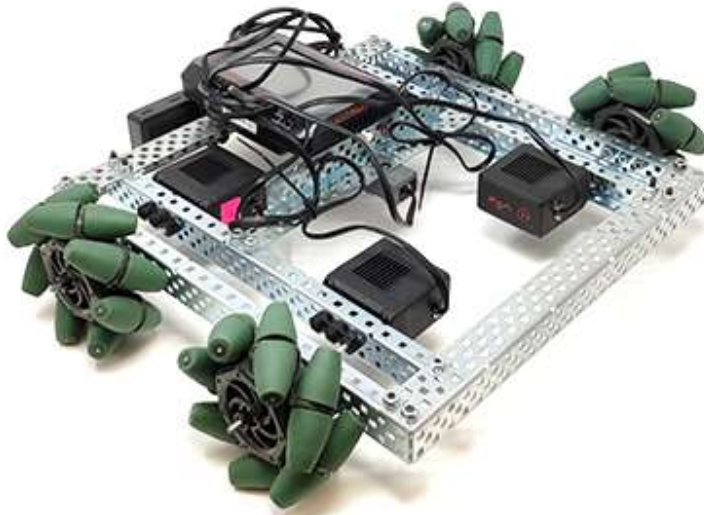

e

Mecanum drive is a type of holonomic drive base; meaning that it applies the force of the wheel at a 45° angle to the robot instead of on one of its axes. By applying the force at an angle to the robot, you can vary the magnitude of the force vectors to gain translational control of the robot; aka, the robot can move in any direction while keeping the front of the robot in a constant compass direction. This differs from the basic robot drive systems like arcade drive, tank drive, or shopping cart drive require you to turn the front of the robot to travel in another direction.

[Mecanum Days Video Link YouTube](#)

DESIGNING IN SOLIDWORKS:

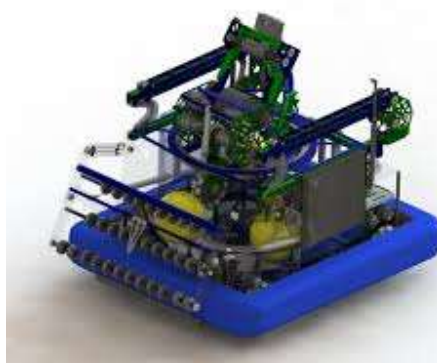

SolidWorks is a popular computer-aided design (CAD) software used for 3D modeling and engineering design. It offers a range of tools and features for creating and simulating mechanical designs. Its significance lies in streamlining the design

process, improving productivity, and facilitating collaboration. Alternative CAD software options include AutoCAD, Fusion 360, and Inventor, each with its own unique features and strengths.

[Complete Solidworks Tutorial](#)

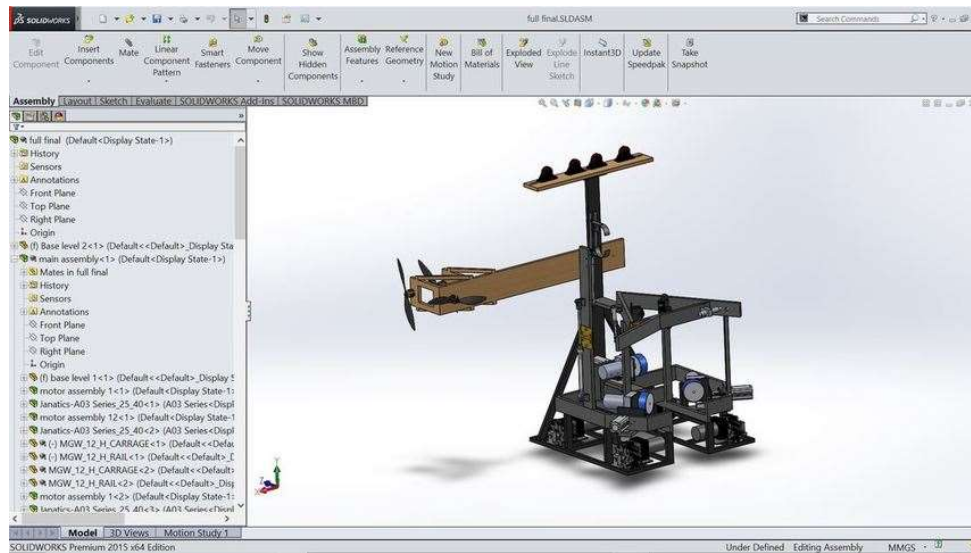

IMAGE PROCESSING

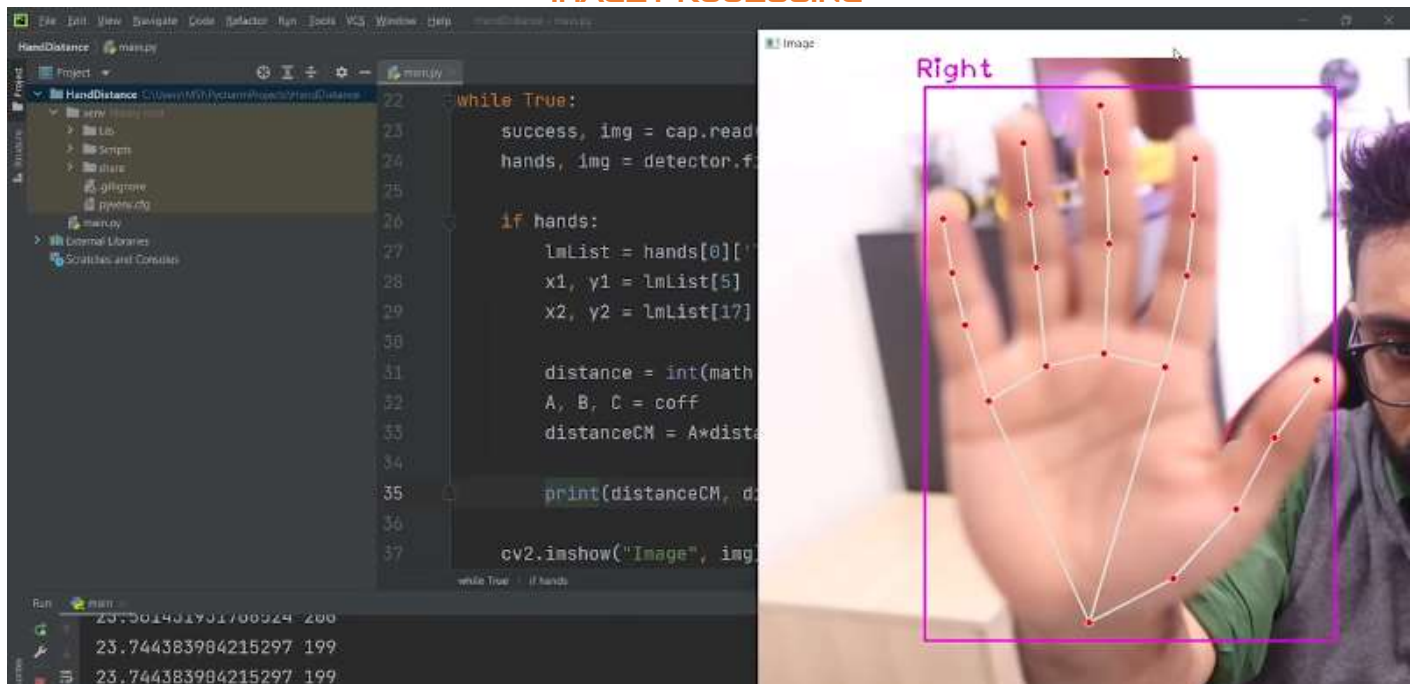

Image processing deals with extracting information or manipulating data from image.

PURPOSE OF IMAGE PROCESSING

The purpose of image processing is divided into 5 groups. They are:

1. Visualization - Observe the objects that are not visible.
2. Image sharpening and restoration - To create a better image.

3. Image retrieval - Seek for the image of interest.
4. Measurement of pattern – Measures various objects in an image.
5. Image Recognition – Distinguish the objects in an image.

TYPES

The two types of **methods used for Image Processing** are **Analog and Digital** Image Processing. Analog or visual techniques of image processing can be used for hard copies like printouts and photographs. Image analysts use various fundamentals of interpretation while using these visual techniques. The image processing is not just confined to an area that has to be studied but to knowledge of analyst. Association is another important tool in image processing through visual techniques. So analysts apply a combination of personal knowledge and collateral data to image processing.

Digital Processing techniques help in manipulation of the digital images by using computers. As raw data from imaging sensors from satellite platforms contains deficiencies. To get over such flaws and to get originality of information, it has to undergo various phases of processing. The three general phases that all types of data have to undergo while using digital technique are Pre- processing, enhancement and display, information extraction.

Go through various feature recognition techniques

mentioned([https://en.wikipedia.org/wiki/Feature_detection_\(computer_vision\)](https://en.wikipedia.org/wiki/Feature_detection_(computer_vision)))

Important ones are:

1. Edge detection
2. Point detection
3. Hough transform
4. Curve detection
5. Colour and background features.

Other Links:-

https://www.tutorialspoint.com/dip/image_processing_introduction.htm

Youtube

videos-<https://www.youtube.com/watch?v=mANUEfTyH3g&list=PLZ9qNFMHZ-A79y1StvUUqgyL-O0fZh2rs&index=2>

Opencv tutorials-https://www.youtube.com/watch?v=hDDR2ewxR1I&list=PLiHa1s-EL3vjr0Z02ihr6Lcu4Q_0rnRvim&index=7

prefer to use opencv in ubuntu . Installing packages are much easier in it.

DRONES AND AVIONICS



LEARN THE BASICS:

Start here

For Concepts ->DroneBlog: <https://www.droneblog.com/start/>

For Drone Building and Specs -DroneNodes <https://dronenodes.com/how-to-build-a-drone/>

The basic parts of a DIY drone include:

- **Quadcopter frame:** This is the structure that holds all the other parts of the drone together. It is typically made of carbon fiber or plastic.
- **Motors:** These are the engines that power the propellers. They are typically brushless motors, which are more efficient and powerful than brushed motors.
- **Electronic Speed Controllers (ESCs):** These are the electronic components that control the speed of the motors. They are essential for ensuring that the motors spin at the correct speed and direction.
- **Flight controller:** This is the brain of the drone. It controls the flight of the drone by receiving input from the sensors and sending output to the ESCs.
- **Propellers:** These are the blades that generate lift and thrust. They are typically made of plastic or carbon fiber.
- **Radio transmitter and receiver:** These are the components that allow you to control the drone remotely. The transmitter sends signals to the receiver, which then controls the flight controller.
- **Battery:** This is the power source for the drone. It is typically a LiPo battery, which is lightweight and provides a lot of power.
- **Optional parts:** There are many other optional parts that you can add to your drone, such as a camera, a gimbal, or a GPS module.
- **Understand the basic components of a drone,** such as the frame, motors, propellers, flight controller, and battery.
- **Familiarize yourself with flight terminology,** including pitch, roll, yaw, and throttle.
- **Explore the different types of drones,** including ready-to-fly (RTF), bind-and-fly (BNF), and do-it-yourself (DIY) kits.

Drone Regulations:

FAMILIARIZE YOURSELF WITH THE DRONE REGULATIONS IN YOUR COUNTRY OR REGION.

Visit the official website of your local aviation authority for guidelines and legal requirements.

In the United States, the Federal Aviation Administration (FAA) provides regulations for recreational and commercial drone operations.

Flight Training:

START WITH A SMALL AND AFFORDABLE DRONE FOR BEGINNERS TO PRACTICE FLYING AND DEVELOP PILOTING SKILLS.

Find open spaces with minimal obstacles to practice flying maneuvers.

Understand the different flight modes and learn how to control the drone manually.

Safety Guidelines:

FOLLOW SAFETY GUIDELINES TO ENSURE RESPONSIBLE AND SAFE DRONE OPERATION.

Maintain a safe distance from people, property, and aircraft.

Check weather conditions and avoid flying in adverse weather.

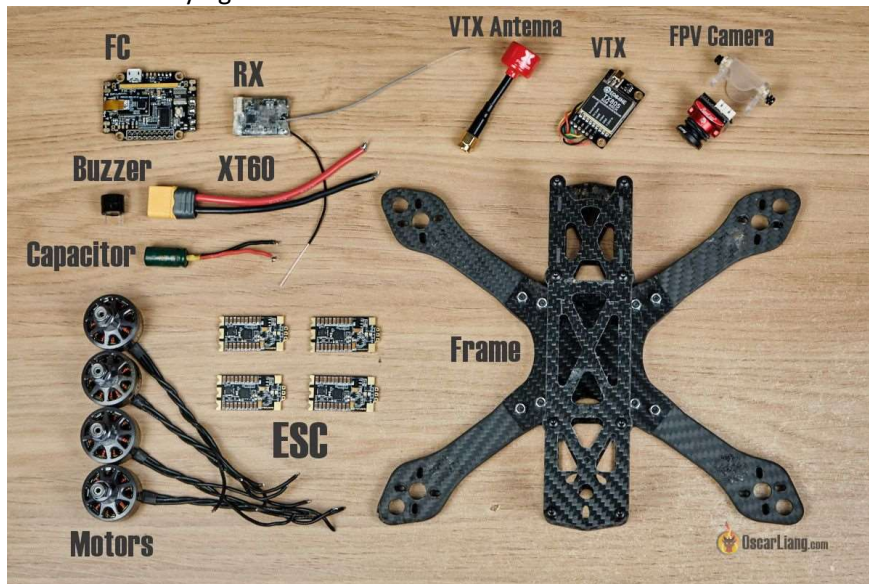

RESOURCES AND COMMUNITIES:

Join online communities and forums dedicated to drone enthusiasts to connect with fellow pilots and gain insights.

Visit websites like DroneDeploy, DIY Drones, and DJI Forum for information, tutorials, and discussions.

Follow YouTube channels specializing in drone reviews, tutorials, and flight demonstrations.

Important Links:

DroneDeploy: <https://www.dronedeploy.com/>

DIY Drones: <https://diydrones.com/>

DJI Forum: <https://forum.dji.com/>

ARTIFICIAL INTELLIGENCE

MACHINE LEARNING

“A computer program is said to learn from experience E with some class of tasks T and performance measure P if its performance at tasks in T, as measured by P, improves with experience E.” -Tom M. Mitchell

Deep Learning is part of Machine Learning. It further has two main branches:

COMPUTER VISION - Also known as Robot vision. Robot Vision involves using a combination of camera hardware and computer algorithms to allow robots to process visual data from the world. For example, your system could have a 2D camera which detects an object for the robot to pick up.

IMAGE PROCESSING - [Computer Vision](#) and [Image Processing](#) are like cousins, but they have quite different aims. Image Processing techniques are primarily used to improve the quality of an image, convert it into another format (like a histogram) or otherwise change it for further processing. Computer Vision, on the other hand, [is more about extracting information from images](#) to make sense of them. So, you might use Image Processing to convert a color image to grayscale and then use Computer Vision to detect objects within that image. ([Tutorials](#))

NATURAL LANGUAGE PROCESSING - Natural language processing (NLP) is a subfield of computer science, information engineering, and artificial intelligence concerned with the interactions between computers and human (natural) languages, in particular how to program computers to process and analyze large amounts of natural language data. Example - A robot may interact via voice commands with use of NLP.

NEURAL NETWORKS - Artificial neural networks (ANN) or connectionist systems are computing systems inspired by the [biological neural networks](#) that constitute animal [brains](#).^[1] The neural network itself is not an algorithm, but rather a framework for many different [machine learning](#) algorithms to work together and process complex data inputs.

Important Links (Courses) :

1. [Andrew NG - Coursera](#)
2. [CS 229](#)
3. **DEEP LEARNING** - [DeepLearning.ai \(Coursera\)](#)
4. **IMAGE PROCESSING** - [OpenCV Tutorials](#)
5. **BOOKS :**

DEEP LEARNING BOOK

INTRODUCTION TO STATISTICAL LEARNING

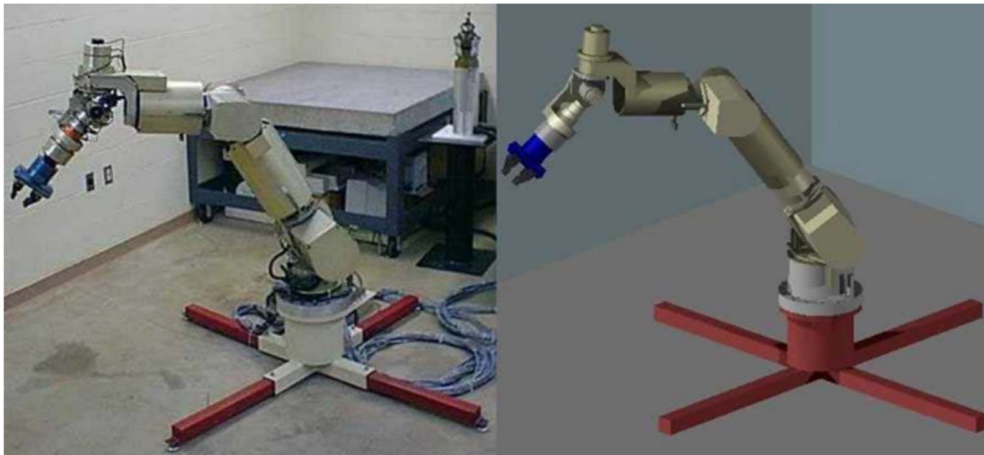

NASA LaRC 8-axis 8R Spatial Serial Manipulator

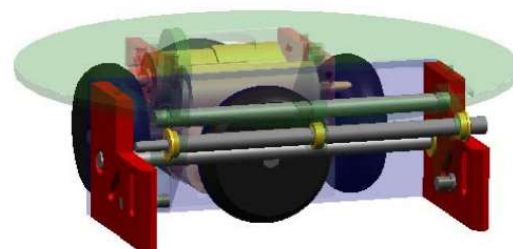
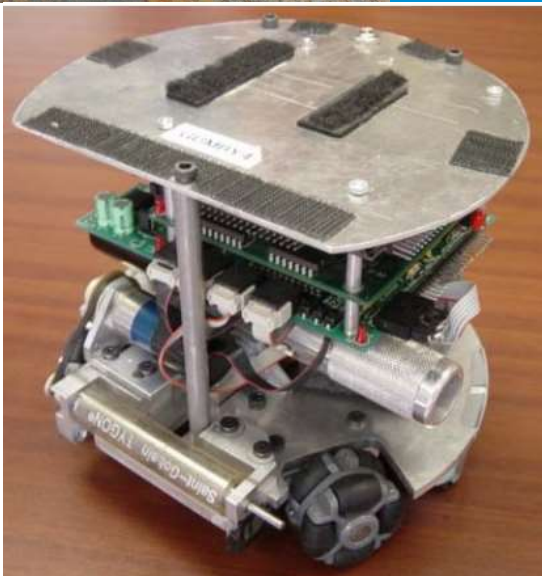
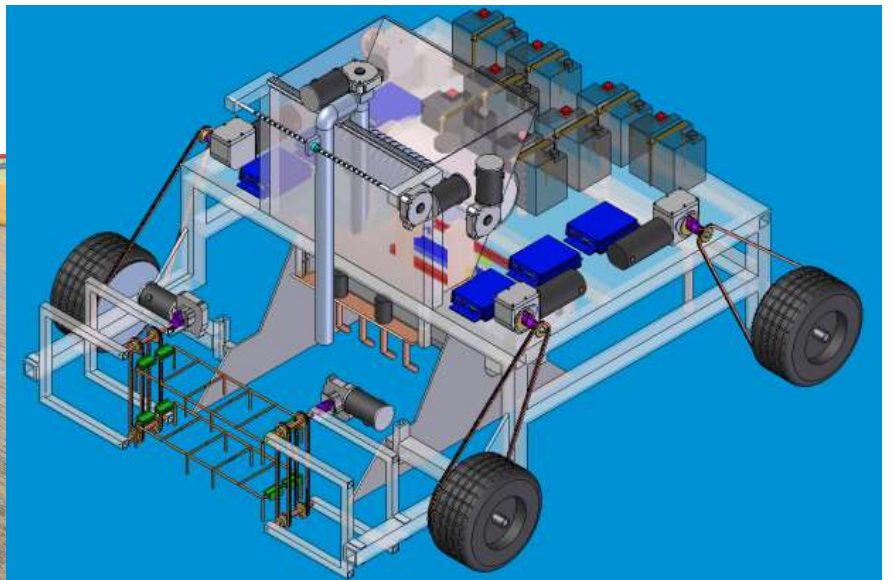
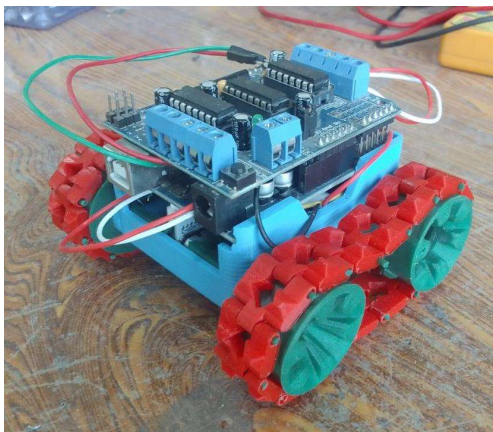

RoboCup Goalie CAD Model

